

## DDM4 - 230 Diamond Core Drill

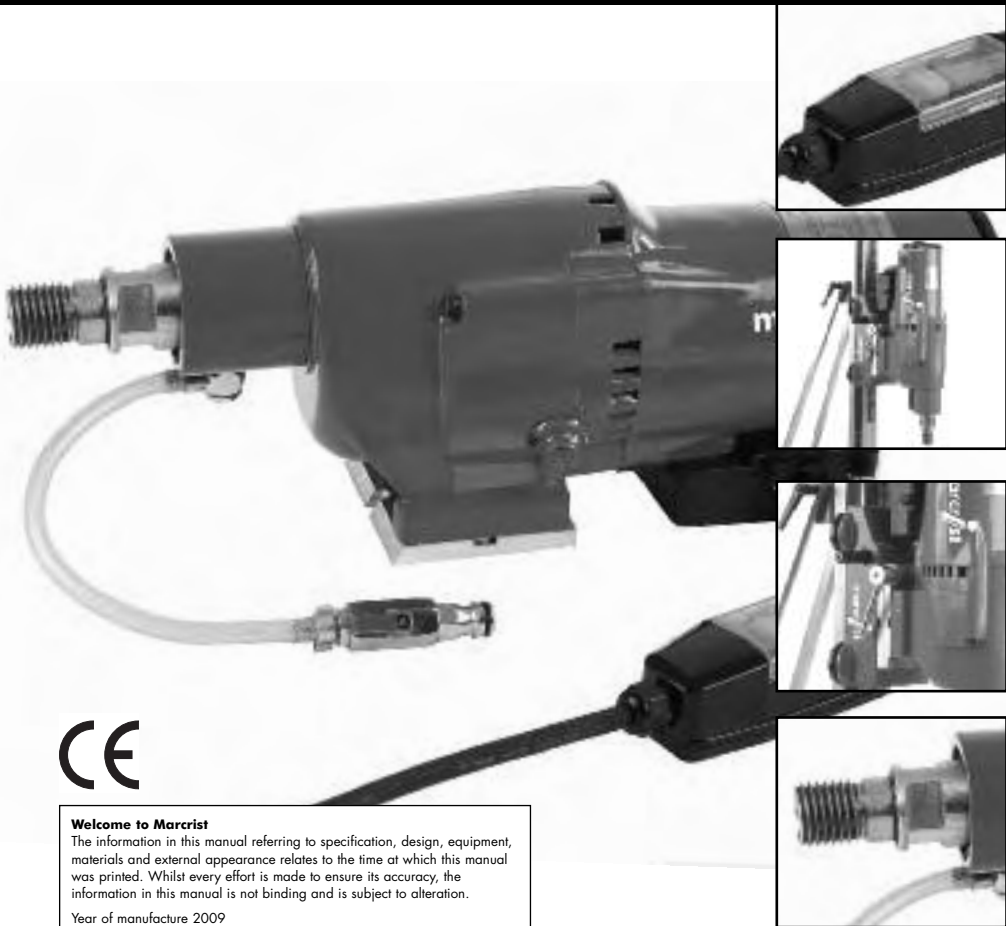

**Welcome to Marcrst**

The information in this manual referring to specification, design, equipment, materials and external appearance relates to the time at which this manual was printed. Whilst every effort is made to ensure its accuracy, the information in this manual is not binding and is subject to alteration.

Year of manufacture 2009

# CONTENTS

ENGLISH	01
DEUTSCH	00
ESPAÑOL	00
FRANÇAIS	00
ITALIANO	00
NEDERLANDS	00

## Congratulations

You have chosen Marcris for your diamond drilling system. We thank you for your choice and confidence!

Marcris has the sole ambition to lead in diamond technology and quality. The Result is outstanding quality for the professional tradesman.

Marcris is accepted worldwide as a technology leader in diamonds. Marcris diamond tools are used by professional tradesmen who value performance, safety and the lowest possible drilling costs.

The best diamond drilling machine is only as good as the cores which are being used. The machine cannot drill if the cores don't drill!

When choosing diamond cores always consider the cost per hole rather than just the lowest purchase price.

A better core may cost a little more but it will invariably last much longer (up to 20 times) and drills at least twice as fast and does not damage the machine!

Because of this, better cores result in costing you between 10–20 times less than cheap cores.

Marcris International Ltd

**Product Management**

## Registration

Register your machine or drill stand within 28 days for its lifetime warranty and 5 years free servicing\* (with service vouchers, which you receive free with every Marcris 850X diamond core drill).

### **How To Register**

To activate the lifetime warranty and 5 years free servicing register your machine or drill stand by mail or via internet . Registration only takes a few minutes. It will save you lots of money.

### **By Mail**

With the enclosed form and envelope.

### **Internet**

[www.marcris.com/registration](http://www.marcris.com/registration).

## Guarantee

### **30 DAYS MONEY BACK GUARANTEE**

If you are not completely satisfied with the performance of your machine or drill stand, simply return it within 30 days, in its original packaging, which is suitable for resale and fit for purpose, to your Marcris distributor, for a full refund.

**Proof of purchase must be produced.**

### **LIFETIME MANUFACTURERS WARRANTY**

If your machine or drill stand becomes defective due to faulty materials or workmanship, we guarantee to replace all defective parts free of charge or, at our discretion, replace the unit free of charge provided that:

- Proof of purchase is produced and the product has been registered.
- The defect is not due to normal wear and tear.
- The product has not been misused and has been serviced regularly.
- Professional quality consumables, capable of drilling hard materials, have been used exclusively.
- Repairs have not been attempted by unauthorised persons.

### **Marcris 5 YEAR FREE MAINTENANCE AND REPAIRS\***

Your machine or drill stand has been designed to operate for a long period of time with a minimum of maintenance.

# Guarantee

Continuous satisfactory and safe operation depends however, upon proper care and maintenance. Regularly, at least every 18 months \*\* take the machine or drill stand to your Marcryst distributor for inspection which includes:

## Machines

- Check up / cleaning
- Clutch re-setting
- Bearing changes
- Seal replacements
- Electrical safety test

## Drill Stands

- Check up / cleaning
- Check operation & guide assembly
- Replace worn parts on guide system

With every Marcryst 850X core purchased you receive a free service voucher. Collect vouchers and, together with the machine or drill stand needing service and your proof of purchase, hand them to your Marcryst distributor. Your distributor will send the machine and vouchers to Marcryst.

### **All you have to do is to pay the postage.**

If the machine or drill stand was beyond repair, Marcryst would, in return for the vouchers, even give you a replacement machine or drill stand, completely free!

The cost of the postage to return the machine or drill stand to you is also covered with the vouchers.

If a machine or drill stand needing service and repair is returned without vouchers, all work and postage will be chargeable at the industry standard rate for power tool repairs.

If you have insufficient vouchers, the repair costs will be reduced as a % of your vouchers. i.e. DDM2 with 5 vouchers would equal 50% off the cost of repairs.

This guarantee is offered as an extra benefit and is in addition to the consumer's statutory rights.

\*With the free service vouchers, Marcryst will, within 5 years from the date of purchase, carry out the service completely free at no charge. All costs for each service and for any parts are covered by the vouchers!

\*\*For your safety the machines & drill stands must be serviced every time you have collected the appropriate amount of vouchers (meaning you will have very extensively used the machine) or, at 18 month intervals. The guarantee may, at the sole discretion of Marcryst, become null and void, if the machine or drill stand is not serviced every appropriate number of cores or within 18 months (whichever is the soonest).

### **Number of vouchers needed for FREE repair, service, safety check, including all parts and labour:**

DDM2 diamond drill – 10 vouchers

DDM3 diamond drill – 15 vouchers

DDM4 diamond drill – 20 vouchers

DS150 drill stand – 5 vouchers

DS250 drill stand – 7 vouchers

# General Power Tool Safety Warnings



**WARNING! When using electric tools basic safety precautions should always be followed to reduce the risk of fire, electric shock and personal injury, including the following. Save all warnings and instructions for future reference.**



Read all these instructions before attempting to operate this product and save these instructions.

Remove the plug before carrying out any adjustment, servicing or maintenance.

## 1. Keep the work area clear

Cluttered areas and benches invite injuries.

## 2. Consider the work area environment

Do not expose tools to rain.

Do not use tools in damp or wet conditions.

Keep the work area well lit.

Do not use tools in the presence of flammable liquid or gases.

## 3. Guard against electric shock

Avoid body contact with earthed or ground surfaces (e.g. pipes, radiators, cookers and refrigerators). Electric safety can be further improved by using a high-sensitivity (30 mA/0.1s) residual current device (RCD).

## 4. Keep other persons away

Do not allow anyone, especially children, not involved in the work touch the tool or the extension cord and keep them away from the work area.

## 5. Store idle tools

When not in use, tools should be stored in a dry locked-up place, out of the reach of children.

## 6. Do not force the tool

It will do the job better and safer at the rate for which it was intended.

## 7. Use the right tool

Do not force small tools to do the job of a heavy duty tool.

Do not use tools for purposes not intended: for example do not use circular saws to cut tree limbs or logs.

## 8. Dress properly

Do not wear loose clothing or jewellery, they can be caught in moving parts.

Non-skid footwear is recommended when working outdoors.

Wear protective hair covering to contain long hair.

## 9. Use protective equipment

Use safety glasses.

Use a face or dust mask if cutting operations create dust.

## 10. Connect dust extraction equipment

If devices are provided for the connection of dust extraction and collecting

equipment, ensure these are connected and properly used.

**11. Do not abuse the cord**

Never yank the cord to disconnect the machine from the socket. Keep the cord away from heat, oil and sharp edges.

**12. Secure work**

Where possible use clamps or a vice to hold the work. It is safer than using your hand.

**13. Do not overreach**

Keep proper footing and balance at all times.

**14. Maintain tools with care**

Keep cutting tools sharp and clean for better and safer performance.

Follow instruction for lubricating and changing accessories.

Inspect tool cords periodically and if damaged have them repaired by an authorized service facility.

Inspect extension cords periodically and replace if damaged.

Keep handles dry, clean and free oil and grease.

**15. Disconnect tools**

When not in use, before servicing and when changing accessories such as blades, bits and cutters, disconnect tools from the power supply.

**16. Remove adjusting keys and wrenches**

Form the habit of checking to see that keys and adjusting wrenches are removed from the tool before turning it on.

**17. Avoid unintentional starting**

Ensure the switch is in the "off" position when plugging in.

**18. Use outdoor extension leads**

When the tool is used outdoors, use only extension cords intended for outdoor use and marked as such.

**19. Stay alert**

Watch what you're doing, use common sense and do not operate the tool when you're tired.

**20. Check damaged parts**

Before further use of tool, it should be carefully checked to determine that it will operate properly.

Check for alignment of moving parts, binding of moving parts, breakage of parts, mounting and any other conditions that may affect its operation.

A guard or other part that is damaged should be properly repaired or replaced by an authorized service centre unless otherwise indicated in this instruction manual.

Have defective switches replaced by authorized service centres,

Do not use the tool if the switch does not turn it on and off.

**21. Warning**

The use of any accessory or attachment other than one recommended in this instruction manual may present a risk of personal injury.

**22. Have your tool repaired by a qualified person**

This electric tool complies with the relevant safety rules. Qualified persons using original spare parts should only carry out repairs, otherwise this may result in considerable danger to the user.

## Operational Safety



Always read the safety instructions & training manual before attempting to operate the DDM4 - 230. Save all warnings and instructions for future reference. Always observe the safety regulations applicable to your country to reduce the risk of fire, electric shock and personal injury.



Safety warning



Always wear safety glasses, dust mask & ear protection



Always wear safety shoes



Always wear safety gloves



**Connection to mains supply shall be made using a residual current device (RCD). Never use the tool without the RCD provided with the tool. Always test the correct operation of the RCD before starting work.**



**Do not drill overhead unless using a water collection system.**

- The DDM4 - 230 is a professional drilling machine capable of drilling up to 250mm diameter and its internal clutch is calibrated to accommodate this.
- When drilling, at all times, care must be taken.
- Make sure that everybody who works with the DDM4 - 230 gets properly instructed to the machine and its instructions prior to use.
- Assess the work area and employ measures to minimise any risks to you or other persons.
- Inspect the machine & accessories before every use. Do not use if there are any defective parts.
- Make sure not to cut through electric mains, gas or water pipes. Use detection systems prior to drilling.
- Make sure all core drills & accessories are fitted correctly as per manufacturers instructions.

- Always check correct rotation of the tool
- Take care to prevent contact with rotating tool
- When drilling downward, make sure the core can drop safely without injuring someone underneath
- When wet drilling use a water cooling device and water collection system. Never perform upward or overhead drilling without the use of a water collection device.
- Do not use the machine in a damp or wet location. Switch off the machine immediately if there is any leak of water.
- Only use clean tap water for cooling purposes
- Prevent water from entering the motor. Make sure the RCD is not in contact with water
- Always use core bits designed for wet drilling
- Always be aware that if the core bit jams the drill may rotate before the clutch engages.
- Never drill from a position where you are not in full control of the DDM4 - 230. Make sure to stand on a stable surface.
- If drilling above chest height, work platforms should be used.
- Never drill from a ladder.
- Always ensure you are working safely and within current legislation and regulations.
- Try to avoid continuous operation and consider a break once in a while. Stop working immediately if you notice a tingle in your hands.



The use of any accessory other than ones listed in this instruction manual or recommended by Marcris may present the risk of personal injury



Above points are to be observed at any time. Failing to comply may result in serious damage or endanger your health. If there are any questions or queries, please contact your dealer.

## Using Instructions

Your DDM4 – 230 machine is supplied so it can be used with Marcris diamond cores & drilling accessories. It has been designed for wet diamond drilling mounted on a drill stand into masonry materials such as brick, breeze block, engineering brick, stone, concrete, & reinforced concrete with wet diamond core bits & a water supply.

Make sure it is mounted safely on a drill stand. The machine should not be used for hand held applications.

### Contents

DDM4 – 230v diamond drilling machine fitted with RCD unit

½" BSP to ½" BSP adaptor

Spanners to help set up and removal of core drills & accessories from the machine.

Instruction manual

Hose for water connection

### Illustrated description of functions

**The main functions of the DDM4 –230 are illustrated in Fig A**

Item	Description
1	Spindle
2	Start – Stop button
3	Gear selector
4	RCD
5	Water Hose Assembly
6	230v Plug
7	Adaptor

### DDM4-230 Drilling Accessories

Part No.	Description
7800.501.002	DS250 Drill Stand
7800.001.001	Anchor Set for Concrete & Brick
7800.001.004/5	Water Collection System
7800.200.002	Quick Release Motor Mount to DS250
7800.001.011	Water Pressure Bottle

# Connection to the power supply

## Electrical safety

The electric motor has been designed for one voltage only. Always check that the power supply corresponds to the voltage on the nameplate.



Do not change the plug unless you are duly authorised to do so!  
Take the DDM4 - 230 to your nearest Marcris Distributor.

## In-line protector RCD

The DDM4 – 230 features a residual current device that cuts off the unit within 15 milliseconds in the event that there is a difference ( $>10$  mA) between the currents flowing in and out of the unit. The user is therefore protected should any water come into contact with any of the electronic components.



**Never use the tool without the RCD provided with the tool. Always test the correct operation of the RCD before starting work (see below).**

To test the RCD unit is working correctly, proceed as follows:

1. Plug in machine into the appropriate power supply (6)
2. Depress the reset button on RCD (4) (Red light indicator is illuminated)
3. Switch on the machine by depressing start button (2).
4. Depress the test button on RCD (4)
5. The switch must break the circuit (red light indicator goes off and machine switches off)
6. RCD is working correctly



If in the test mode the switch does not break the circuit DO NOT USE.  
Take the DDM4 - 230 to your nearest Marcris Distributor to arrange inspection & repair



It is not permitted to make any modifications to the machine, in particular it is not allowed to open the RCD or to repair or to replace the cable. If it is need of inspection or repair take to your nearest Marcris distributor



Never use the RCD as a main switch. Always switch the RCD on under no load condition.



If an extension cable is to be used always ensure it is of an approved type for the application and the cable is of a minimum rating for the machine. Always operate extension cord with the cable reel fully unwound.



Use in ambient conditions

It is not recommended to use your DDM4 machine in conditions that are extreme hot or extreme cold. Do not use the machine in wet conditions.

## Connection to drill stand



Prior to assembly or adjustment of DDM4-230 to the DS250 drill stand always unplug the tool

The DDM4-230 drilling machine can only be used on a drill stand. It should never be used in hand held applications. It has been designed to fit the Marcris DS250 Drill Stand. This should be by means of a Quick Release Precision Motor Mount DS250 available separately from Marcris (part no. 7800.200.002) or a motor fixing plate for the DDM4 (available with DS250 drill stand)



Also refer to the DS250 drill stand manual

### Initial Set Up

#### Fixing the Quick Release Motor Mount to the DS250 Drill Stand. (Fig B, C, D)

Item	Description
8	Top Jacking Screw Assembly
9	Eye Bolt
10	Column
11	Crank Assembly
12	Carriage
13	Socket head screws
14	Quick release motor mount
15	Flat base plate
16	Countersunk screws
17	Locking handle
18	Motor fixing plate DDM4
19	Key bar
20	Fixing screws (x4)
21	DDM4 base
22	Carriage lock knob

- Remove eye bolt (9) from drill stand column (10)
- Remove top jacking screw assembly (8)
- Unlock carriage by pulling & twisting carriage lock knob at the back (22)
- Raise carriage (12) on column (10) by turning crank handle (11) until it reaches the top. Remove carriage (12) from column (10)
- Fix the Quick Release Motor mount (14) to the carriage by locating the key bar (19) into the carriage & by using the 4 socket head screws (13). Tighten with an Allen key

- Fix the flat base plate component (15) of the Motor Mount to the base of the DDM4-230 by locating the key bar (19) & by using the 4 countersunk screws (16)
- Replace the carriage (12) with the motor mount (14) back on the column (10) replacing the top jacking screw assembly (9) & eye bolt (8).
- Use the crank handle (11) to lower the carriage (12) back into position.
- Lock carriage by pushing & twisting carriage lock knob (22)

### **Fixing DDM4-230 to Quick Release Motor Mount on DS250 (Fig E, F)**

- Attach the DDM4-230 to the motor mount (14) by placing the angled edge of the flat plate (15) fixed on the base of the DDM4-230 into the groove on the Motor Mount and push the DDM4-230 forward. Secure in place by turning the handle (17) until it locks.



Always ensure the DDM4-230 is mounted firmly & securely on the DS250 drill stand to prevent movement.

- When drilling is completed. Disconnect power. Remove cores & accessories from DDM4-230 using spanners provided.
- Unlock DDM4-230 from Quick Release Motor Mount by turning the handle (17) to release
- Remove DDM4-230 safely from the drilling stand
- Keep the Motor Mount on the DS250 for next use. It is not necessary to remove this every time drilling is completed.

### **Fixing the DDM4 to DS250 using Motor Fixing Plate (Fig G)**

- Remove carriage (12) from column (10) as above.
- Fix the motor fixing plate (18) to the carriage by locating the key bar (19) into the carriage. Place the 4 fixing screws (20) through the back of the carriage.
- Locate a key bar (19) into the base of the DDM4 (21)
- Locate the 4 fixing screws, motor fixing plate and carriage into the base of the DDM4 machine (21)
- Tighten the screws with an Allen key.
- Replace the carriage (12) with the fixed DDM4 back on the column (10) replacing the top jacking screw assembly (8) & eye bolt (9)
- Use the crank handle (11) to lower the carriage (12) & DDM4 back into position.
- Lock carriage & DDM4 by pushing & twisting carriage lock knob (22)

## Operating Instructions



**Follow all safety instruction and observe any relevant regulations. Also refer to DS250 drill stand & wet drilling accessories manual.**

### Work piece and working area



Always ensure that materials to be drilled are securely supported and stable and will not move during operation. Ensure that the core drill selected is suitable for the material being drilled.



Ensure work place and operators position are safe, tidy & organised in a way not to hamper the drilling action. Be aware of the location of pipe work, wiring, fixture and fittings.



Ensure the DDM4-230 mounted on the DS250 drilling stand is fixed securely to the material being drilled by means of an Anchor Kit (7800.001.001) or vacuum kit. Both available from Marcris. If the drilling stand is to be fixed by a vacuum grip fixing device then this shall never be used alone for drilling in unstable positions such as on vertical walls and on the ceiling.

### Gear Selection

1. Ensure power supply is off. When selecting any gear rotate the drill spindle (1) slowly while turning the selector (3) to the appropriate speed. This will ensure smooth selection of gear.
2. Do not change gears when the tool is rotating and in use. Failure to follow this instruction could result in damage to the machine.
3. See speed chart on page 16. Adjust the speed for harder / softer materials accordingly. Lower speeds should be used for harder materials, higher speed for softer materials

### Assembly & operation

1. Prior to operation fix the DDM4-230 to the DS250 drill stand (as above) & mark the area where the hole is to be drilled
2. Plug in machine into the appropriate power supply (6)
3. Test correct operation of RCD (4) unit before use (see above)
4. Disconnect power. For core drills with 1/2" BSP thread, screw 1/2" BSP adaptor (7) into drill spindle (1)
5. Screw core drill with 1/2" BSP thread onto adaptor (7)
6. For core drills with 1 1/4" UNC thread, screw directly into drill spindle (1)

- 7.** To operate the machine depress the start / stop button (2)
- 8.** Slowly feed the core drill into the workpiece using the feed handle of the DS250
- 9.** At the start of the drilling, apply light pressure to allow the core drill to mark a hole
- 10.** Apply only gentle pressure during operation. Excessive force may damage the machine or accessories and could result in a shortening of tool life.
- 11.** Continue drilling until hole is drilled
- 12.** Take extra care when the core drill is about to break through the surface to prevent splintering
- 13.** To stop drilling depress start / stop button (2).
- 14.** Disconnect the power from the supply.
- 15.** Remove the core from DDM4 – 230 or adaptor (1 or 7) using the spanners provided.

## Accessories

Drilling aids and accessories are available from Marcris. Contact your Marcris dealer for more information

Always follow the manufactures guidelines when attaching accessories to the machine.

## Connection to water supply for wet drilling on drilling stands. (Fig H)

Certain very hard materials such as reinforced concrete can present problems for dry drilling. They may cause excessive heat & consequent polishing (blunting) of the diamond segment on the core.

This can result in poor drilling performance and can be overcome by connection of a suitable water supply onto the hose of the DDM4 machine (5) using a "Gardena" or "Hozelock" type fitting as shown in Figure H.

1. Connect the 350mm long water hose (5) on DDM4 - 230 to a suitable water supply by push fitting into a "Gardena" or "Hozelock" type fitting which is attached to a hose pipe. The hose pipe could be typically between 5m - 20m in length.
2. Check that all connections are tightened firmly before operation.
3. Turn on water supply.
4. Turn on tap on the water hose so that a steady flow of water cools the segments on the core.
5. The water tap on the hose (5) can be adjusted to increase or reduce the flow of cooling water towards the core drill.

Note: If no mains water is available an 11L water pressure bottle with 2m hose and connect coupling is available from Marcris (part no. 7800.001.011)



Do not exceed the recommended maximum water pressure of 2 bar.



The hose (5) should always be checked that it is in a satisfactory condition before use and is not split and does not leak water. **DO NOT USE IF THE HOSE IS LEAKING WATER OR IS DAMAGED.**

A minimal flow of water direct to the core segments & material helps cool the drilling area & improve drilling performance.



Keep water away from the parts of the tool & away from persons in the working area.



Always test the correct operation of the RCD before starting work. Never use the tool without the DCD delivered with the machine



If the plug or supply cable needs replacing then take the DDM4 - 230 to your nearest Marcris Distributor.

## Maintenance

Your Marcris diamond-drilling machine is manufactured to the highest possible standards. Continuous satisfactory operation depends upon the proper servicing and maintenance of the drilling machine. If your machine needs repair take the DDM4-230 to your nearest Marcris dealer. Do not have your tool repaired by an unqualified person.

For your safety the machine must be serviced every time you have collected 20 vouchers (meaning you will have very extensively used the machine) or, at 18 month intervals. The guarantee may, at the sole discretion of Marcris, become null and void, if the machine is not serviced every 20 cores or within 18 months (whichever is the soonest).



If replacement of the supply cable or plug is necessary, take the DDM4 - 230 to your nearest Marcris Distributor to avoid a safety hazard.



Only replace fuse with one of the same type & appropriate rating (Max 13A)

Keep the ventilation slots clear of dust and foreign objects. Regularly clean the machine with a damp cloth. Do not use chemicals to clean the machine.

## Emissions

### Sound Levels

Level of sound pressure measured according to EN61029-1 : 2000 + A11 + A12 & EN ISO 3744

LpA (sound pressure level) 95.6 dB (A)

LwA (sound power level) 108.6dB (A)

Uncertainty K : 3 dB (A)



Always take suitable measures for the protection of your hearing.

# Technical Data

Technical data	DDM4 - 230	
Voltage	230 V	
Power Input	2450 W	
No load speed		
1st gear	500 min <sup>-1</sup>	
2nd gear	920 min <sup>-1</sup>	
Maximum drilling diameter with diamond core bits	Gear	Wet
	1	ø91-255mm
	2	ø22-90mm

Outer thread 1 1/4" UNC (32mm) Inner thread 1/2" BSP (19mm)

Spindle thread

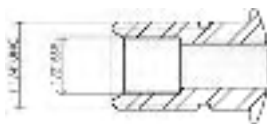

Maximum diameter shown on the label only applies to Marcris core drills. By using low quality core drills the maximum usable diameter will be reduced.

Weight	25.2kg(max)
--------	-------------

**!** Modification which could lead to a change from the original characteristics of the machine. Eg. rotational speed or maximum diameter of the core drill bit may only be done by the manufacturer.

**WARNING** - Read all safety warnings designated by the **!** symbol and all instructions. Failure to follow the warnings and instructions may result in electric shock, fire and/or serious injury.

## Torque limiting clutch

The DDM4 - 230 is equipped with a torque-limiting clutch that reduces the maximum torque reaction transmitted to the operator in case of jamming of a core bit. This feature also prevents the gearing and electric motor from stalling. The torque-limiting clutch has been factory-set.

## CE-Declaration of conformity

Marcris declares that the DDM4 - 230 Drilling Machine conforms to all current standards and directives EN 61029-1:2000 + A11 + A12, EN55014-1: 2006, EN55014-2/A1: 2001, EN61000-3-2: 2006, EN61000-3-11: 2000, 98/37/EC, 2006/95/EC, 2004/108/EC. A detailed certificate of conformity is available upon request.



## Recycling

According to WEEE directive 2002/96/EC, old machinery should be returned for recycling or safe disposal when they eventually become to be thrown away (see symbol on nameplate of the drill). Separate collection of used products and packaging allows materials to be recycled and used again. Re-use of recycled materials helps prevent environmental pollution and reduces the demand for raw materials. Ensure that the old tool is returned to Marcrist International Ltd and does not end up in unsorted municipal solid waste.

## Spare Parts List (Fig J)

Item	Description	Part Number
1	Gearbox / Shaft Assembly	7760.200.001
2	Motor 230v	7760.200.002
2	Motor 110v	7760.200.003
3	Intermediate casting	7760.200.004
4	Clutch Shaft Assembly	7760.200.005
5	Gear Selector Assembly	7760.200.006
6	Rear Motor Cover	7760.200.007
7	Switch Assembly 230v	7760.200.008
7	Switch Assembly 110v	7760.200.009
8	Lead with plug 110v	7760.200.011
9	Lead with RCD Plug 230v GB	7760.200.010
9	Lead with RCD Plug 230v DE	7760.200.012
9	Lead with RCD Plug 230v CH	7760.200.013
10	Brush Housing	7760.200.020
11	Motor Brushes 230v	7760.200.021
11	Motor Brushes 110v	7760.200.022
12	Water hose and tap assembly	7700.200.008
13	Adaptor ½" BSP to ½" BSP	340.101.0023

## Technical Hotline

### For all your technical queries:

Technical Hotline UK:	+44 (0) 1302 893 253
Technical Hotline Germany:	+49 (0) 7741 966 720
Technical Hotline Switzerland:	+41 (0) 41 630 25 43

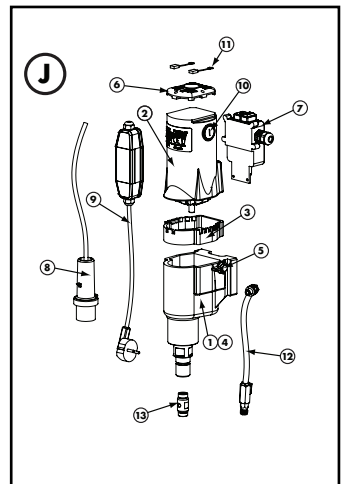
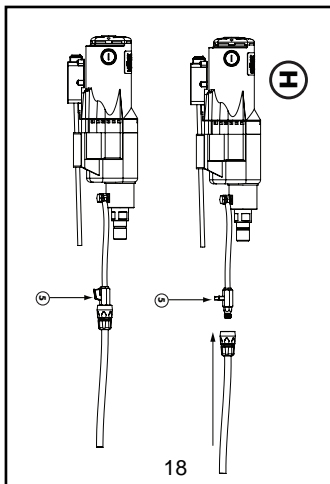
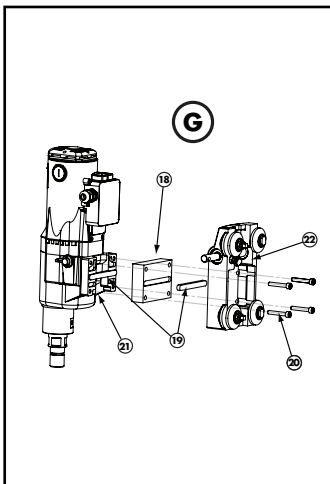
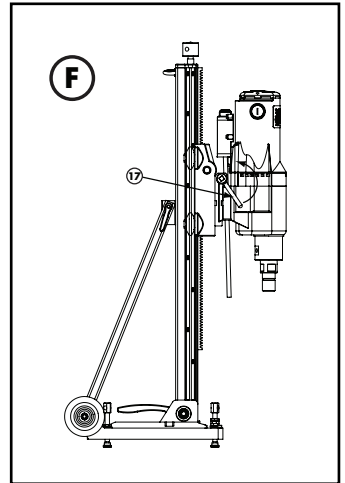
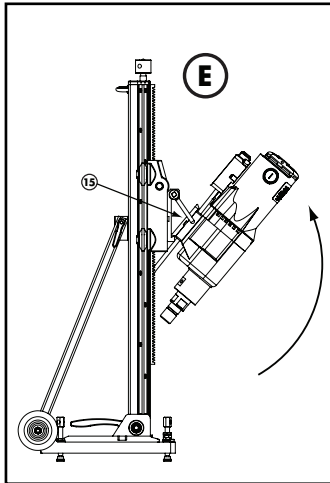
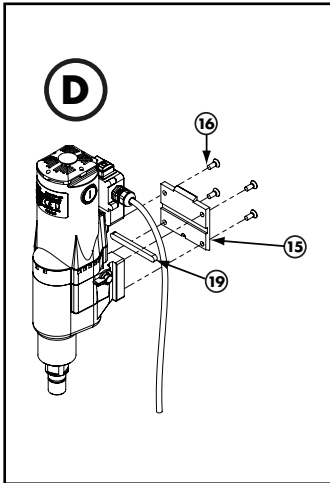
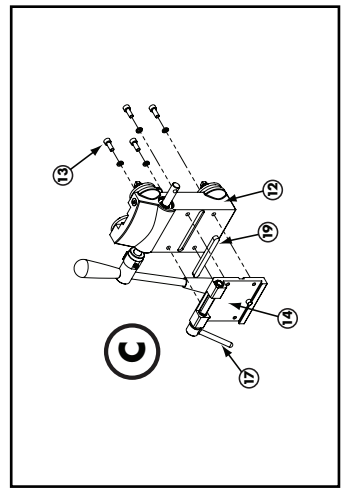
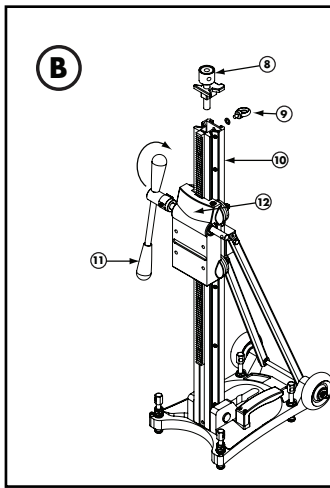
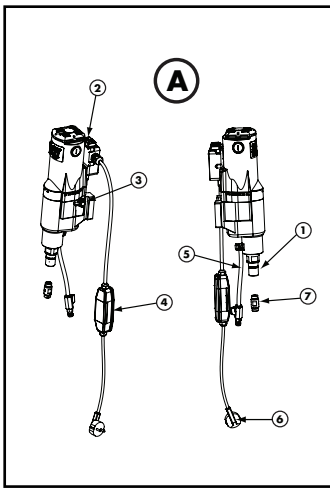



MarcrisT International Limited  
MarcrisT House  
Kirk Sandall Industrial Estate  
Doncaster DN3 1QR  
England  
**T:** +44 (0)1302 890888  
**F:** +44 (0)1302 883864  
**E:** [info@marcrisT.com](mailto:info@marcrisT.com)  
**W:** [www.marcrisT.com](http://www.marcrisT.com)

MarcrisT Diamantwerkzeuge  
Vertriebsgesellschaft mbH  
Karl-Benz-Str. 8  
79761 Waldshut-Tiengen  
Deutschland  
**T:** +49 (0)7741 966 72 0  
**F:** +49 (0)7741 966 72 99  
**E:** [info@marcrisT.de](mailto:info@marcrisT.de)  
**W:** [www.marcrisT.com](http://www.marcrisT.com)

MarcrisT Diamantwerkzeuge GmbH  
Postfach 37  
5322 Koblenz  
Schweiz  
**T:** +41 (0)41 630 25 43  
**F:** +41 (0)41 630 25 63  
**E:** [info@marcrisT.ch](mailto:info@marcrisT.ch)  
**W:** [www.marcrisT.com](http://www.marcrisT.com)