

Threading with taps

NOMENCLATURE

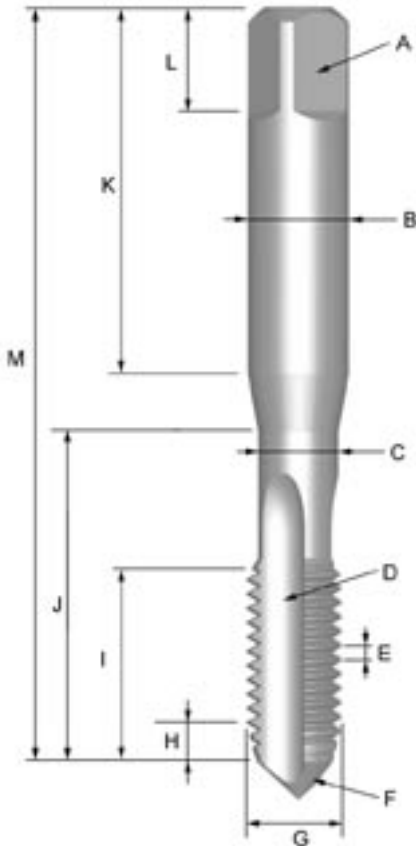

- A Square Across Flat
- B Shank Diameter
- C Recess Diameter
- D Flute
- E Pitch
- F External Centre (Male)
- G Thread Diameter (External)
- H Chamfer Lead Length
- I Thread Length
- J Recess Length
- K Shank Length
- L Square Length
- M Overall Length
- N Helix angle
- O Spiral Point Length
- P Spiral Point Angle
- Q Chamfer Lead Angle

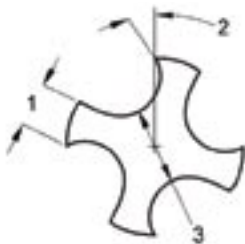

- 1 Land Width
- 2 Cutting Rake Angle
- 3 Web Diameter
- 4 Radial Thread Relief













GENERAL HINTS ON TAPPING

The success of any tapping operation depends on a number of factors, all of which effect the quality of the finished product.















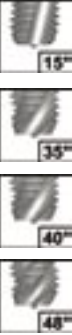

1. Select the correct design of tap for the component material and type of hole, i.e. through or blind, from the Application Material Groups chart.
2. Ensure the component is securely clamped - lateral movement may cause tap breakage or poor quality threads.
3. Select the correct size of drill from the tapping drill charts (see pages 76 - 79). The correct sizes of drill are also shown in the tap pages of the catalogue. Remember the drill sizes for fluteless taps are different. Always ensure that work hardening of the component material is kept to a minimum, see stainless steel part in General Information section.
4. Select the correct cutting speed as shown in the Visual Index in the Catalogue and in the Product Selector.
5. Use appropriate cutting fluid for correct application.
6. In NC applications ensure that the feed value chosen for the program is correct. When using a tapping attachment, 95% to 97% of the pitch is recommended to allow the tap to generate its own pitch.
7. Where possible, hold the tap in a good quality torque limiting tapping attachment, which ensures free axial movement of the tap and presents it squarely to the hole. It also protects the tap from breakage if accidentally 'bottomed' in a blind hole.
8. Ensure smooth entry of the tap into the hole, as an uneven feed may cause 'bell mouthing'.

Threading with taps











TAP GEOMETRIES AND TAPPING PROCESS

Type	Variants	Process	Description	Chips
		  1,5xD	Taps with straight flutes Straight flutes are the most commonly used type of tap. Suitable for use on most materials, mainly short chipping steel and cast iron, they form the basis of the program.	
		  2xD	Taps with interrupted thread The interrupted thread ensures less friction and therefore less resistance, which is particularly important when threading material which is resilient and difficult to machine (e.g. aluminium, bronze). It is also easier for lubricant to penetrate to the cutting edges, thus helping to minimise the torque generated.	
		  2,5xD	Spiral point taps The tap has a straight fairly shallow flute and is often referred to as a gun nose or spiral point tap. The gun nose or spiral point is designed to drive the swarf forward. The relatively shallow flutes ensure that the sectional strength is maximised. They also act to allow lubricant to reach the cutting edges. This type of tap is recommended for threading through holes.	

Threading with taps

Type	Variants	Process	Description	Chips
		 	<p>Taps with flutes only on the chamfer lead</p> <p>The cutting part of the tap is formed by gun nosing in the same manner as for a spiral point tap, the function being to drive the swarf forward ahead of the cutting edges. This design is extremely rigid which facilitates good machining results. However, the short length of the gun nosing limits its application to a depth of hole less than about 1.5 x Ø.</p>	
		  	<p>Taps with spiral flutes</p> <p>Taps with spiral flutes are intended primarily for threading in blind holes. The helical flute transports the swarf back away from the cutting edges and out of the hole, thus avoiding packing of swarf in the flutes or at the bottom of the hole. In this way, danger of breaking the tap or damaging the thread is minimised.</p>	
		 	<p>Cold forming taps</p> <p>Cold forming taps differ from cutting taps in that the thread is produced by plastic deformation of the component material rather than by the traditional cutting action. This means that no swarf is produced by their action. The application range is materials with good formability. Tensile strength (R_m) should not exceed 1200 N/mm² and the elongation factor (A₅) should not be less than 10%.</p> <p>Cold forming taps without flutes are suitable for normal machining and are especially suitable when vertically tapping blind holes. They are also available with through coolant.</p>	

Threading with taps

Type	Variants	Process	Description	Chips
		  2,5xD  3xD	<p>Through coolant taps</p> <p>The performance of taps with through coolant holes is higher than the same taps used with external lubrication. These kinds of taps allow better evacuation of the chip, which is transported away from the cutting area itself. Wear on the cutting edge is reduced, since the cooling effect on the cutting zone is higher than the heat generation.</p> <p>Lubrication can be oil, emulsion or air pressurised with oil mist. Working pressure not less than 15 bar is required, but good results can be obtained with minimal lubrication.</p>	
		  D₁₈₋₂₀ C 2-3  2xD	<p>Nut taps</p> <p>These taps are generally used to thread nuts but can be used also on deep through holes. They have a shank diameter smaller than the nominal and a longer overall length, because their function is to accumulate nuts.</p> <p>They are used on special machines designed to thread huge amounts of nuts. They can work in steel and stainless steel.</p> <p>The first serial tap has a very long chamfer, in order to spread the cutting load on almost two thirds of the thread length.</p>	

POINT/CHAMFER MATRIX

The type of point on taps is up to the producer to choose. Below is a chart showing the points and chamfers that are commonly used together on products from Dormer, sorted by the diameter of the tap.

Types of Point				
1	2	3	4	
Full Point	Reduced point	Internal point	Removed point	

Chamfer Form					
Tap \varnothing mm	A 6 - 8	B 3,5 - 5	C 2 - 3	D 18 - 20	E 1,5 - 2
≤ 5	1	1	1	1	1
$>5 \leq 6$	1	1	1, 2	1	1
$>6 \leq 10$	1, 2	1	1, 2, 4	1, 2	1, 4
$>10 \leq 12$	2, 3	2, 3	2, 3	2, 3	2, 3
>12	3	3	3	3	3
ANSI	Taper	Plug	Bottoming		

THREAD (OR COLD) FORMING GEOMETRIES AND PROCESS

Advantages compared with cutting taps

- Cold forming is faster than ordinary thread cutting.
- Cold forming taps often give a longer tool life.
- One type of tool can be used in different materials and for both through and blind holes.
- Cold forming taps have a stable design which gives lower risk of breakage.
- Threads to the correct tolerance are guaranteed.
- No chips.
- Stronger thread (higher stripping strength), compared to thread obtained by cutting (up to 100% more).
- Lower surface roughness on thread obtained by forming than by cutting.

Pre-conditions for effective use

- Sufficient material elongation
 $A_g > 10\%$
- Precise drilled hole diameter.
- Good lubrication is imperative.

Threading with taps

FLOW OF MATERIAL WHEN FORMING A THREAD

The tapping hole size depends upon the material being drilled, the cutting conditions selected and the condition of the equipment being used. If material is pushed up at the thread entry by the tap and/or the life of the tap is too short, select a slightly larger drill diameter. If on the other hand the profile of the thread formed is insufficient, then select a slightly smaller drill diameter.



Section of thread obtained by forming tap on steel C45

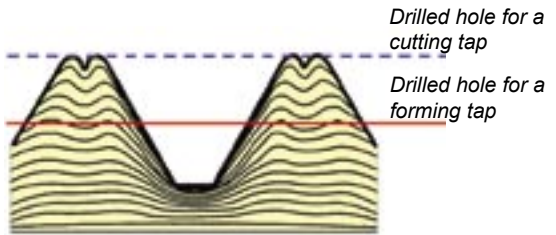



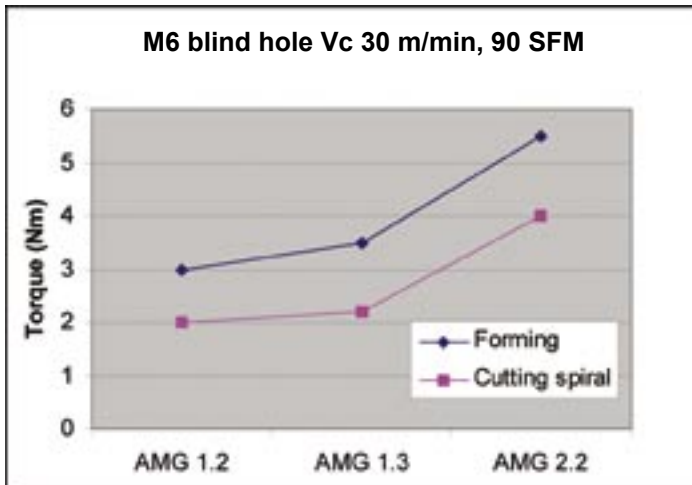



















Cold forming taps require more power on the spindle, compared to a cutting tap of the same size, since it generates higher torque.



Torque comparison between forming and cutting taps in different material groups.

Threading with taps

VANGARD / SHARK COLOUR RINGS APPLICATION TAPS

Colour	Material	Tool types available
	AMG 1.1 – AMG 1.4	
	AMG 1.1 – 1.5	
	AMG 1.4 – 1.6	
	AMG 1.5 – 1.6 AMG 4.2 – 4.3	
	AMG 2.1 – AMG 2.3	  
	AMG 3.1 – AMG 3.4	
	AMG 5.1 – 5.3	 
	AMG 7.1 – 7.4	   

Threading with taps

THREAD PROFILES

ISO-threads

Metric threads, M

Unified threads, UN

H	=	0,86603 P
H _m	=	5/8H = 0,54127 P
H _s	=	17/24H = 0,613343 P
H/8	=	0,10825 P
H/4	=	0,21651 P
R	=	H/6 = 0,14434P

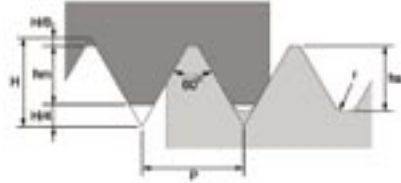

Whitworth W (BSW)

BSF, G, Rp, ADMF, Brass 1/4

BS Conduit, ME

H	=	0,96049 P
H	=	2/3H = 0,64033 P
H/6	=	0,16008 P
R	=	0,13733 P

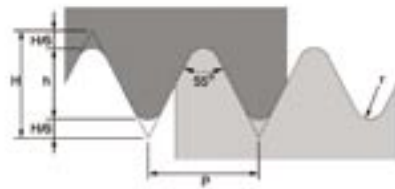

Whitworth conical pipe threads

Rc (BSPT), Conical 1:16

H	=	0,96024 P
H	=	2/3H = 0,64033 P
R	=	0,13728 P

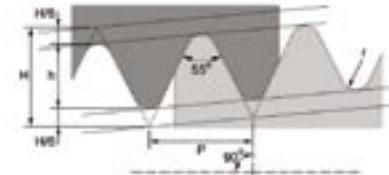

American conical pipe threads

NPT, Conical 1:16

H	=	0,8668 P
H	=	0,800 P
H/24	=	0,033 P (min. value)



Steel conduit threads

PG (Pr)

H	=	0,59588 P
H	=	0,4767 P
R	=	0,107 P



Threading with taps

TOLERANCES

THREAD TOLERANCE WITH TAPS FOR METRIC ISO 60° THREAD PROFILE (M+UN)

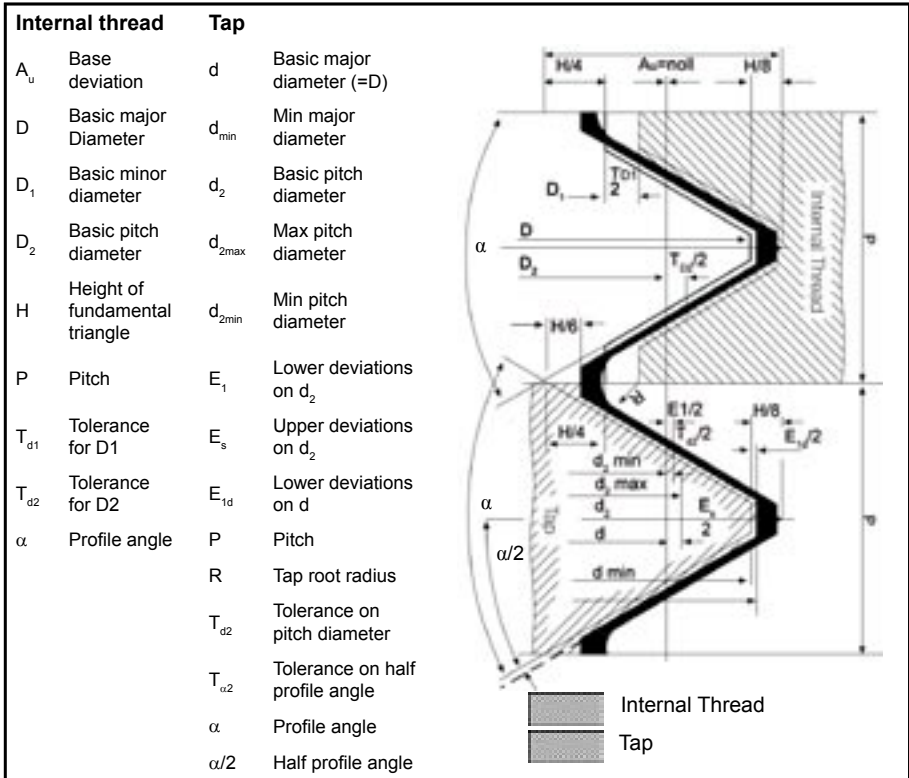

USUAL TOLERANCES FOR TAPS AND INTERNAL THREAD

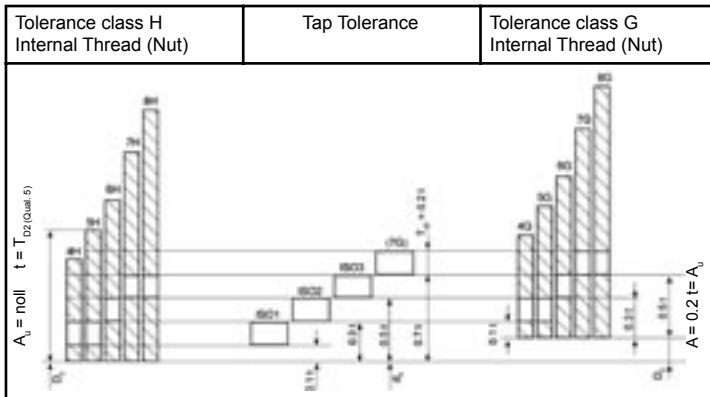

Threading with taps

TABLE OVER TAP TOLERANCE VS TOLERANCE ON INTERNAL THREAD (NUT)

Tolerance class, Tap			Tolerance, Internal thread (Nut)					Application
ISO	DIN	ANSI BS						
ISO 1	4 H	3 B	4 H	5 H				Fit without allowance
ISO 2	6 H	2 B	4 G	5 G	6 H			Normal fit
ISO 3	6 G	1 B			6 G	7 H	8 H	Fit with large allowance
-	7 G	-				7 G	8 G	Loose fit for following treatment or coating

Thread tolerances for taps are collected in standard reference DIN 13.

Normal tolerance is ISO 2 (6H) on taps, which generates an average quality fit between screw and nut. Lower tolerance (ISO 1) generates a fine fit without a gap on the flanks between screw and nut. Higher tolerance (ISO 3) generates a rough fit, with large gap. It is used in the case of a nut which will later be coated or if a loose fit is preferred.

Between tolerances 6H (ISO2) and 6G (ISO3), as well as between 6G and 7G, the tap manufacturer produces taps with tolerance 6HX and 6GX. "X" means the tolerance is outside standard and it is used for taps working high strength material or abrasive material such as cast iron. These materials do not cause oversize problems, so higher tolerance can be used in order to increase tool life. The width of the tolerance is equal between, for example, 6H and 6HX.

Forming taps are usually produced with a 6HX or 6GX tolerance.

The tolerance icon for BSW and BSF is medium. This refers to BS 84 "medium fit".

Pipe threads with the tolerance icon "Normal" refer to the following standards:

G threads to ISO 228-1. One class for internal thread (tap), and class A and B for external thread (die).

R, Rc and R threads to ISO 7-1.









NPT and NPSM to ANSI B1.20.1.

NPTF and NPSF to ANSI B1.20.3.

PG to DIN 40 430.

CHAMFER LENGTHS AND SERIAL TAPS

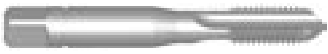
The first group (No. 1, No. 2, No. 3) includes taps with complete thread profile and the difference is in the chamfer length. The second group (No. 4, No. 5) includes taps with incomplete thread profile. They have lower pitch and outer diameter, compared to the complete standard, and longer chamfer. After using them, a finishing tap No. 3, must be used.

No. 1 =		6-8 x P	
No. 2 =		4-6 x P	
No. 3 =		2-3 x P	
No. 4 =		6-8 x P	
No. 5 =		3,5-5 x P	



ISO	Set code number	Including tap number
	No. 6	No. 1 + No. 2 + No. 3
	No. 7	No. 2 + No. 3
	No. 8	No. 4 + No. 5 + No. 3
	No. 9	No. 5 + No. 3

DIN	Set code number	Including tap number
	No. 8	No.3 (form C) + No.4 (form A) + No.5 (form B)
	No. 9	No.3 (form C) + No.5 (form B)

ANSI	Set code number	Including tap number
	Hand Tap (No. 6)	Taper(No.1) + Plug(No.2) + Bottoming(No.3)

Threading with taps

DRILL DIAMETERS FOR CUTTING TAPS – RECOMMENDATION TABLES

Drill diameter can be calculated from:

D = Drill diameter (mm)

D_{nom} = Tap nominal diameter (mm)

P = Tap pitch (mm)

$$D = D_{nom} - P$$

ISO METRIC COARSE THREAD					ISO METRIC FINE THREAD						
TAP	Max. Internal Pitch	DRILL Diam.	DRILL Diam.	DRILL Diam.	TAP	Max. Internal Diam.	DRILL Diam.	DRILL Diam.	DRILL Diam.		
M	mm	mm	mm	inch	MF	mm	mm	inch	mm		
1.6	0.35	1.321	1.25	3/64	3x0.35	2.721	2.65	37	25X1	24.153	24
1.8	0.35	1.521	1.45	54	3.5x0.35	3.221	3.2	1/8	25X1.5	23.676	23.5
2	0.4	1.679	1.6	1/16	4x0.5	3.599	3.5	29	25x2	23.210	23
2.2	0.45	1.833	1.75	50	5x0.5	4.599	4.5	16	26x1.5	24.676	24.5
2.5	0.45	2.138	2.05	46	5.5x0.50	5.099	5	9	27x1.5	25.676	25.5
3	0.5	2.599	2.5	40	6x0.75	5.378	5.3	5	27x2	25.210	25
3.5	0.6	3.010	2.9	33	7x0.75	6.378	6.3	D	28x1.5	26.676	26.5
4	0.7	3.422	3.3	30	8x0.75	7.378	7.3	9/32	28x2	26.210	26
4.5	0.75	3.878	3.8	27	8x1	7.153	7	J	30x1.5	28.676	28.5
5	0.8	4.334	4.2	19	9x1	8.153	8	O	30x2	28.210	28
6	1	5.153	5	9	10x0.75	9.378	9.3	U	32x1.5	30.676	30.5
7	1	6.153	6	15/64	10x1	9.153	9	T	32x2	30.210	30
8	1.25	6.912	6.8	H	10x1.25	8.912	8.8	11/32	33x2	31.210	31
9	1.25	7.912	7.8	5/16	11x1	10.153	10	X	35x1.5	33.676	33.5
10	1.5	8.676	8.5	Q	12x1	11.153	11	7/16	36x1.5	34.676	34.5
11	1.5	9.676	9.5	3/8	12x1.25	10.912	10.8	27/64	36x2	34.210	34
12	1.75	10.441	10.3	Y	12x1.5	10.676	10.5	Z	36x3	33.252	33
14	2	12.210	12	15/32	14x1	13.153	13	17/32	38x1.5	36.676	36.5
16	2	14.210	14	35/64	14x1.25	12.912	12.8	1/2	39x3	36.252	36
18	2.5	15.744	15.5	39/64	14x1.5	12.676	12.5	31/64	40x1.5	38.676	38.5
20	2.5	17.744	17.5	11/16	15x1	14.153	14	35/64	40x2	38.210	38
22	2.5	19.744	19.5	49/64	15x1.5	13.676	13.5	17/32	40x3	37.252	37
24	3	21.252	21	53/64	16x1	15.153	15	19/32	42x1.5	40.676	40.5
27	3	24.252	24	61/64	16x1.5	14.676	14.5	9/16	42x2	40.210	40
30	3.5	26.771	26.5	1.3/64	18x1	17.153	17	43/64	42x3	39.252	39
33	3.5	29.771	29.5	1.5/32	18X1.5	16.676	16.5	41/64	45x1.5	43.676	43.5
36	4	32.270	32	1.1/4	18X2	16.210	16	5/8	45X2	43.210	43
39	4	35.270	35	1.3/8	20X1	19.153	19	3/4	45X3	45.252	42
42	4.2	37.799	37.5		20X1.5	18.676	18.5	47/64	48X1.5	46.676	46.5
45	4.5	40.799	40.5		20X2	18.210	18	45/64	48X2	46.210	46
48	5	43.297	43		22X1	21.153	21	53/64	48X3	45.252	45
52	5	47.297	47		22X1.5	20.676	20.5	13/16	50X1.5	48.686	48.2
					22X2	20.210	20	25/32	50X2	48.210	48
					24X1	23.153	23	29/32	50X3	47.252	47
					24X1.5	22.676	22.5	7/8			
					24X2	22.210	22	55/64			

RECOMMENDED DIAMETERS WHEN USING DORMER ADX AND CDX DRILLS

These tables for drill diameters refer to ordinary standard drills. Modern drills such as Dormer ADX and CDX produce a smaller and more accurate hole which makes it necessary to increase the diameter of the drill in order to avoid breakage of the tap. Please see the small table to the right.

ISO METRIC COARSE THREAD FOR ADX/CDX

TAP	Pitch	DRILL Diameter	TAP	Pitch	DRILL Diameter
M	mm	mm	M	mm	mm
4	0.70	3.40	10	1.50	8.70
5	0.80	4.30	12	1.75	10.40
6	1.00	5.10	14	2.00	12.25
8	1.25	6.90	16	2.00	14.25

DRILL DIAMETERS FOR CUTTING TAPS – RECOMMENDATION TABLES

ISO UNIFIED COARSE THREAD

TAP	Max. Internal Diam. mm	DRILL Diam. mm	DRILL Diam. Inch
UNC			
nr 2-56	1.872	1.85	50
nr 3-48	2.146	2.1	47
nr 4-40	2.385	2.35	43
nr 5-40	2.697	2.65	38
nr 6-32	2.896	2.85	36
nr 8-32	3.513	3.5	29
nr 10-24	3.962	3.9	25
nr 12-24	4.597	4.5	16
1/4-20	5.268	5.1	7
5/16-18	6.734	6.6	F
3/8-16	8.164	8	5/16
7/16-14	9.550	9.4	U
1/2-13	11.013	10.8	27/64
9/16-12	12.456	12.2	31/64
5/8-11	13.868	13.5	17/32
3/4-10	16.833	16.5	21/32
7/8-9	19.748	19.5	49/64
1-8	22.598	22.25	7/8
1.1/8-7	25.349	25	63/64
1.1/4-7	28.524	28	1.7/64
1.3/8-6	31.120	30.75	1.7/32
1.1/2-6	34.295	34	1.11/32
1.3/4-5	39.814	39.5	1.9/16
2-41/2	45.595	45	1.25/32

ISO UNIFIED FINE THREAD

TAP	Max. Internal Diam. mm	DRILL Diam. mm	DRILL Diam. Inch
UNF			
nr 2-64	1.913	1.9	50
nr 3-56	2.197	2.15	45
nr 4-48	2.459	2.4	42
nr 5-44	2.741	2.7	37
nr 6-40	3.023	2.95	33
nr 8-36	3.607	3.5	29
nr 10-32	4.166	4.1	21
nr 12-28	4.724	4.7	14
1/4-28	5.580	5.5	3
5/16-24	7.038	6.9	I
3/8-24	8.626	8.5	Q
7/16-20	10.030	9.9	25/64
1/2-20	11.618	11.5	29/64
9/16-18	13.084	12.9	33/64
5/8-18	14.671	14.5	37/64
3/4-16	17.689	17.5	11/16
7/8-14	20.663	20.4	13/16
1-12	23.569	23.25	59/64
1.1/8-12	26.744	26.5	1.3/64
1.1/4-12	29.919	29.5	1.11/64
1.3/8-12	33.094	32.75	1.19/64
1.1/2-12	36.269	36	1.27/64

WHITWORTH COARSE THREAD

TAP	Number of t.p.i.	Max. Internal Diam. mm	DRILL Diam. mm
BSW			
3/32	48	1.910	1.85
1/8	40	2.590	2.55
5/32	32	3.211	3.2
3/16	24	3.744	3.7
7/32	24	4.538	4.5
1/4	20	5.224	5.1
5/16	18	6.661	6.5
3/8	16	8.052	7.9
7/16	14	9.379	9.2
1/2	12	10.610	10.5
9/16	12	12.176	12
5/8	11	13.598	13.5
3/4	10	16.538	16.5
7/8	9	19.411	19.25
1	8	22.185	22
1.1/8	7	24.879	24.75
1.1/4	7	28.054	28
1.3/8	6	30.555	30.5
1.1/2	6	33.730	33.5
1.5/8	5	35.921	35.5
1.3/4	5	39.098	39
1.7/8	4.1/2	41.648	41.5
2	4.1/2	44.823	44.5

CYLINDRICAL WHITWORTH PIPE THREAD

TAP	Number of t.p.i.	Max. Internal Diam. mm	DRILL Diam. mm
G			
1/8	28	8.848	8.8
1/4	19	11.890	11.8
3/8	19	15.395	15.25
1/2	14	19.172	19
5/8	14	21.128	21
3/4	14	24.658	24.5
7/8	14	28.418	28.25
1	11	30.931	30.75
1.1/4	11	39.592	39.5
1.1/2	11	45.485	45
1.3/4	11	51.428	51
2	11	57.296	57
2.1/4	11	63.342	63
2.1/2	11	72.866	72.5
2.3/4	11	79.216	79
3	11	85.566	85.5

ISO METRIC COARSE INSERT THREAD

TAP	DRILL Diameter mm
EG M	
2.5	2.6
3	3.2
3.5	3.7
4	4.2
5	5.2
6	6.3
8	8.4
10	10.5
12	12.5
14	14.5
16	16.5
18	18.75
20	20.75
22	22.75
24	24.75

ISO UNIFIED COARSE INSERT THREAD

TAP	DRILL Diam. mm
EG UNC	
nr 2-56	2.3
nr 3-48	2.7
nr 4-40	3
nr 5-40	3.4
nr 6-32	3.7
nr 8-32	4.4
nr 10-24	5.1
nr 12-24	5.8
1/4-20	6.7
5/16-18	8.4
3/8-16	10
7/16-14	11.7
1/2-13	13.3

Threading with taps

DRILL DIAMETERS FOR CUTTING TAPS – RECOMMENDATION TABLES

CYLINDRICAL AMERICAN PIPE THREAD					CYLINDRICAL AMERICAN PIPE THREAD "DRYSEAL"			TAPERED WHITWORTH PIPE THREAD		
TAP	Min Internal Diam mm	Max. Internal Diam. mm	Rec. Drill mm	Rec. Drill Inch	TAP	Min Internal Diam mm	Recommended Drill Diam. mm	TAP	Number of t.p.i.	DRILL Diam. mm
NPSM					NPSF			Rc		
1/8"-27	9.039	9.246	9.10	23/64	1/8"-27	8.651	8.70	1/8	28	8.4
1/4"-18	11.887	12.217	12.00	15/32	1/4"-18	11.232	11.30	1/4	19	11.2
3/8"-18	15.316	15.545	15.50	39/64	3/8"-18	14.671	14.75	3/8	19	14.75
1/2"-14	18.974	19.279	19.00	3/4	1/2"-14	18.118	18.25	1/2	14	18.25
3/4"-14	24.333	24.638	24.50	31/32	3/4"-14	23.465	23.50	5/8	14	20.25
1"-11.1/2	30.506	303.759	30.50	1.13/64	1"-11.1/2"	29.464	29.50	3/4	14	23.75
1.1/4"-11.1/2	39.268	39.497	39.50	1. 9/16				7/8	14	27.5
1.1/2"-11.1/2	45.339	45.568	45.50	1.51/64				1	11	30
2"-11.1/2	57.379	57.607	57.50	2. 1/4				1.1/8	11	34.5
2.1/2"-8	68.783	69.266	69.00	2.23/32				1.1/4	11	38.5
3"-8	84.684	85.166	85.00	3.3/8				1.3/8	11	41
								1.1/2	11	44.5
								1.3/4	11	50
								2	11	56
								2.1/4	11	62
								2.1/2	11	71.5
								2.3/4	11	78
								3	11	84

TAPERED AMERICAN PIPE THREAD				TAPERED AMERICAN PIPE THREAD "DRYSEAL"			ARMOUR PIPE THREAD			
TAP	Number of t.p.i.	DRILL Diam. mm	DRILL Diam. Inch	TAP	Number of t.p.i.	DRILL Diam. mm	TAP	Number of t.p.i.	Max. Internal Diam. mm	DRILL Diam. mm
NPT				NPTF			PG			
1/16	27	6.3	D	1/8	27	8.4	7	20	11.45	11.4
1/8	27	8.5	R	1/4	18	10.9	9	18	14.01	13.9
1/4	18	11	7/16	3/8	18	14.25	11	18	17.41	17.25
3/8	18	14.5	37/64	1/2	14	17.75	13.5	18	19.21	19
1/2	14	18	23/32	3/4	14	23	16	18	21.31	21.25
3/4	14	23	59/64	1	11.1/2	29	21	16	27.03	27
1	14	29	1.5/32	1.1/4	11.1/2	37.75	29	16	35.73	35.5
1.1/4	11.1/2	38	1.1/2	1.1/2	11.1/2	43.75	36	16	45.73	45.5
1.1/2	11.1/2	44	1.47/64	2	11.1/2	55.75	42	16	52.73	52.5
2	11.1/2	56	2.7/32	2.1/2	8	66.5	48	16	58.03	58
2.1/2	8	67	2.5/8	3	8	82.5				
3	8	83	3.1/4							

Threading with taps

DRILL DIAMETERS FOR COLD FORMING TAPS – RECOMMENDATION TABLES

Drill diameter can be calculated from:

$$D = D_{nom} - 0,0068 * P * 65$$

D = Drill diameter (mm)

D_{nom} = Tap nominal diameter (mm)

P = Tap pitch (mm)

65 in the formula stands for desired thread height in %

ISO METRIC COARSE THREAD			
TAP	Max. Internal Diam. mm	DRILL Diameter mm	DRILL Diameter Inch
M			
2	1.679	1.8	
2.5	2.138	2.3	
3	2.599	2.8	35
3.5	3.010	3.2	30
4	3.422	3.7	
5	4.334	4.6	14
6	5.153	5.5	7/32
8	6.912	7.4	
10	8.676	9.3	
12	10.441	11.2	7/16
14	12.210	13.0	
16	14.210	15.0	

ISO METRIC FINE THREAD			
TAP	Max. Internal Diam. mm	DRILL Diameter mm	
MF			
4x0.50	3.599	3.8	
5x0.50	4.599	4.8	
6x0.75	5.378	5.7	
8x0.75	7.378	7.7	
8x1.00	7.158	7.5	
10x1.00	9.153	9.5	
10x1.25	8.912	9.4	
12x1.00	11.153	11.5	
12x1.25	10.9912	11.4	
12x1.50	10.676	11.3	
14x1.00	13.153	13.5	
14x1.25	12.912	13.4	
14x1.50	12.676	13.3	
16x1.00	15.153	15.5	
16x1.50	14.676	15.25	

ISO UNIFIED COARSE THREAD			
TAP	Max. Internal Diam. mm	DRILL Diam. mm	DRILL Diam. Inch
UNC			
nr 1-64	1.582	1.7	51
nr 2-56	1.872	2	47
nr 3-48	2.148	2.3	
nr 4-40	2.385	2.6	39
nr 5-40	2.697	2.9	33
nr 6-32	2.896	3.2	1/8
nr 8-32	3.513	3.8	25
nr 10-24	3.962	4.4	11/64
nr 12-24	4.597	5	9
1/4-20	5.268	5.8	
5/16-18	6.734	7.3	
3/8-16	8.164	8.8	11/32
7/16-14	9.550	10.3	Y
1/2-13	11.013	11.9	.463

ISO UNIFIED FINE THREAD			
TAP	Max. Internal Diam. mm	DRILL Diam. mm	DRILL Diam. Inch
UNF			
nr 1-72	1.613	1.7	51
nr 2-64	1.913	2.0	
nr 3-56	2.197	2.3	
nr 4-48	2.459	2.6	37
nr 5-44	2.741	2.9	33
nr 6-10	3.023	3.2	1/8
nr 8-36	3.607	3.9	24
nr 10-32	4.166	4.5	16
nr 12-28	4.724	5.1	7
1/4-28	5.588	6	A
5/16-24	7.038	7.5	.293
3/8-24	8.626	9.1	
7/16-20	10.030	10.6	Z
1/2-20	11.618	12.1	.476

Threading with taps

SHANK DESCRIPTION



ISO SHANK AND SQUARE DIMENSIONS

Shank diameter mm	Square mm	ISO 529 Metric	ISO 529 UNC/UNF BSW/BSF	ISO2283 Metric	ISO2284 G	ISO2284 Rc	
2,50	2,00	M1					
		M1,2					
		M1,4					
		M1,6	No. 0				
		M1,8					
2,80	2,24	M2	No. 1				
		M2,2	No. 2				
3,15	2,50	M2,5	No. 3				
		M3	No. 4 No. 5	M3			
3,55	2,80	M3,5	No. 6	M3,5 M4			
4,00	3,15	M4		M5			
4,50	3,55	M4,5	No. 8	M6			
5,00	4,00	M5	No. 10 3/16				
5,60	4,50	M5,5	No. 12 7/32	M7			
6,30	5,0	M6	¼	M8			
7,10	5,60	M7	9/32				
8,00	6,30	M8	5/16	M10	G 1/8	Rc 1/8	
9,00	7,10	M9		M12			
10,00	8,00	M10	3/8		G ¼	Rc ¼	
8,00	6,30	M11	7/16				
9,00	7,10	M12	½				
11,20	9,00	M14	9/16	M14			
12,50	10,00	M16	5/8	M16	G 3/8	Rc 3/8	
14,00	11,20	M18	11/16	M18			
		M20	¾	M20			
16,00	12,50	M22	7/8	M22			
18,00	14,00	M24	1"	M24	G 5/8	Rc 5/8	
20,00	16,00	M27	1 1/8	M27	G ¾	Rc ¾	
		M30		M30			
22,40	18,00	M33	1 ¼		G 7/8	Rc 7/8	
25,00	20,00	M36	1 3/8		G 1"	Rc 1"	
28,00	22,40	M39	1 ½				
		M42					



DIN SHANK AND SQUARE DIMENSIONS

Shank diameter mm	Square mm	DIN 352	DIN 371	DIN 376	DIN 374	DIN 2182	DIN 2183	DIN 353 DIN 374
2,5	2,1	M1	M1					
		M1,1	M1,1					
		M1,2	M1,2	M3,5	M3,5	1/16		
		M1,4	M1,4					
		M1,6	M1,6					
2,8	2,1	M1,8	M1,8					
		M2	M2					
		M2,2	M2,2	M4	M4	3/32	5/32	
		M2,5	M2,5					
3,20	2,4						3/16	
3,50	2,70	M3	M3	M5	M5			
4,00	3,00	M3,5	M3,5			1/8		
4,50	3,40	M4	M4	M6	M5,5 M6	5/32	¼	
6,00	4,90	M5 M6 M8	M5 M6	M8	M8	3/16	5/16	
7,00	5,50	M10		M10	M9 M10	¼	3/8	G 1/8
8,00	6,20		M8			5/16	7/16	
9,00	7,00	M12		M12	M12	3/8	½	
10,00	8,00		M10					
11,00	9,00	M14		M14	M14		9/16	G ¼
12,00	9,00	M16		M16	M16		5/8	G 3/8
14,00	11,00	M18		M18	M18		¾	
16,00	12,00	M20		M20	M20			G ½
18,00	14,50	M22 M24		M22 M24	M22 M24		7/8	G 5/8
20,00	16,00	M27		M27	M27 M28		1"	G ¾
22,00	18,00	M30		M30	M30		1 1/8	G 7/8
25,00	20,00	M33		M33	M33		1 ¼	G 1"
28,00	22,00	M36		M36	M36		1 3/8	G 1 1/8
32,00	24,00	M39		M39	M39		1 ½	G 1 ¼
		M42		M42	M42	1 5/8		
		M45		M45	M45	1 ¾		
36,00	29,00	M48		M48	M48		1 7/8	G 1 ½
		M52		M52		2		
40,00	32,00							G 1 ¾
45,00	35,00							G 2"
50,00	39,00							G 2 ¼
								G 2 ½
								G 2 ¾
								G 3"

Threading with taps



ANSI SHANK AND SQUARE DIMENSIONS

Shank diameter inch	Square inch	ASME B94.9 machine screw sizes	ASME B94.9 fract. sizes	ASME B94.9 metric sizes
0,141	0,11	No 0		M 1.6
		No 1		M 1.8
		No 2		M 2
		No 3		M 2.5
		No 4		
		No 5		M 3
		No 6		M 3.5
0,168	0,131	No 8		M 4
0,194	0,152	No 10		M 5
0,22	0,165	No 12		
0,255	0,191		¼	M 6
0,318	0,238		5/16	M 7
				M 8
0,381	0,286		3/8	M 10
0,323	0,242		7/16	
0,367	0,275		½	M 12
0,429	0,322		9/16	M14
0,48	0,36		5/8	M16
0,542	0,406		11/16	M18
0,59	0,442		¾	
0,652	0,489		13/16	M20
0,697	0,523		7/8	M22
0,76	0,57		15/16	M24
0,8	0,6		1	M 25
0,896	0,672		1 1/16	M27
			1 1/8	
1,021	0,766		1 3/16	M30
			1 ¼	
1,108	0,831		1 5/16	M33
			1 3/8	
1,233	0,925		1 7/16	M36
			1 ½	
1,305	0,979		1 5/8	M39
1,43	1,072		1 ¾	M42
1,519	1,139		1 7/8	
1,644	1,233		2	M48

TROUBLE SHOOTING WHEN TAPPING

Problem	Cause	Remedy
Oversize	Incorrect tolerance	Choose a tap with lower thread tolerance
	Incorrect axial feed rate	Reduce feed rate by 5-10% or increase compression of tap holder
	Wrong type of tap for application	Use spiral point for through hole or spiral flute for blind hole. Use coated tool to prevent built up edge. Check Catalogue or Product Selector for correct tool alternative
	Tap not centered on the hole	Check tap holder and position tap centre on the hole
	Lack of lubrication	Use good lubrication in order to prevent built up edge. See lubricant section
	Tap speed too slow	Follow recommendation in Catalogue / Product Selector
Undersize	Wrong type of tap for application	Use spiral point for through hole or spiral flute for blind hole. Use coated tool to prevent built up edge. Use tap with higher rake angle. Check Catalogue or Product Selector for correct tool alternative
	Incorrect tolerance	Choose a tap with higher tolerance, especially on material with low oversize tendency, such as cast iron, stainless steel
	Incorrect or lack of lubricant	Use good lubrication in order to prevent chip blockage inside the hole. See lubricant section
	Tap drill hole too small	Increase drill diameter to the maximum value. See tap drill tables
	Material closing in after tapping	See recommendation in Catalogue / Product Selector for correct tool alternative
Chipping	Wrong type of tap for application	Choose a tap with lower rake angle. Choose a tap with longer chamfer. Use spiral point taps for through hole and spiral flute for blind holes, in order to avoid chip blockage. Check Catalogue or Product Selector for correct tool alternative
	Incorrect or lack of lubricant	Use good lubrication in order to prevent built up edge. See lubricant section
	Taps hit bottom of hole	Increase depth of drilling or decrease depth of tapping
	Work hardening surface	Reduce speed, use coated tool, use good lubrication. See section for machining of stainless steel
	Swarf trapping on reversal	Avoid sudden return of tap on reversal motion
	Chamfer hits hole entrance	Check axial position and reduce axial error of tap point on hole centre.
	Tap drill hole too small	Increase drill diameter to maximum value. See tap drill tables

Threading with taps

Problem	Cause	Remedy
Breakage	Tap worn out	Use a new tap or regrind the old one
	Lack of lubricant	Use good lubrication in order to prevent built up edge and chip blockage. See lubricant section
	Taps hit bottom of hole	Increase depth of drilling or decrease depth of tapping
	Tap speed too high	Reduce cutting speed. Follow recommendation in Catalogue / Product Selector
	Work hardening surface	Reduce speed. Use coated tool Use good lubrication. See section for machining of stainless steel
	Tap drill hole too small	Increase drill diameter up to maximum value. See tap drill tables
	Too high torque	Use tapping attachment with torque adjustment clutch
	Material closing in after tapping	See recommendation in Catalogue / Product Selector for correct tool alternative
Rapid wear	Wrong type of tap for application	Use tap with lower rake angle and/or higher relief and/or longer chamfer. Use coated tool. Check Catalogue or Product Selector for correct tool alternative
	Lack of lubricant	Use good lubrication in order to prevent built up edge and thermal stress on cutting edge. See lubricant section
	Tap speed too high	Reduce cutting speed. Follow recommendation in Catalogue / Product Selector
Built up edge	Wrong type of tap for application	Use tap with lower rake angle and/or higher relief. Check Catalogue or Product Selector for correct tool alternative
	Lack of lubricant	Use good lubrication in order to prevent built up edge. See lubricant section
	Surface treatment not suitable	See section for surface treatment recommendations
	Tap speed too low	Follow recommendation in Catalogue / Product Selector

